

technical details

- 3 point cat 2
- hydraulic drive of the knives, oil consumption from 25 liters per row
- exact height guidance by adjustable feeler wheels
- free swinging housing universal suitable for single and double dams
- optionally with own on-board hydraulics
- optionally with swivel arm for staggered working in the foil tunnel

model name	application area	total weight
R-ED/DD	single row	290 kg
R2-ED	two rows	410 kg
R3-ED	three rows suitable for narrow wheeltrack	520 kg
RK4-ED	four-row hydraulic folding without own oil supply	700 kg
RK4-ED	four-row hydraulic folding with own oil supply	810 kg

optionally with swivel arm

1,6 m swivel range offset by one row	130 kg extra weight for R-ED and R-DD
2,0 m swivel range offset by two rows	150 kg extra weight for R-ED and R2-ED
3,2 m swivel range offset by several rows	200 kg extra weight for R-DD

goal of processing

- Suction and cutting of tendrils on the embankment flank
- Targeted shortening of the lateral leaf mass
- Reduction of wage labor costs

farming is you.

We are **4DISC** - a community of farmers, fruit growers and machine builders who solve typical problems in agriculture and fruit growing.

We are happy to help! Further information can be found at www.4disc.de.

4DISC

4 Disc GmbH
Bönninghauser Str. 5
44329 Dortmund

☎ +49 231 986 923 22
✉ 4disc@4disc.de
www.4disc.de ●

11/2022

4DISC RANEX ●



The innovative
tendril cutter

Remove tendrils
**economically and
effectively.**

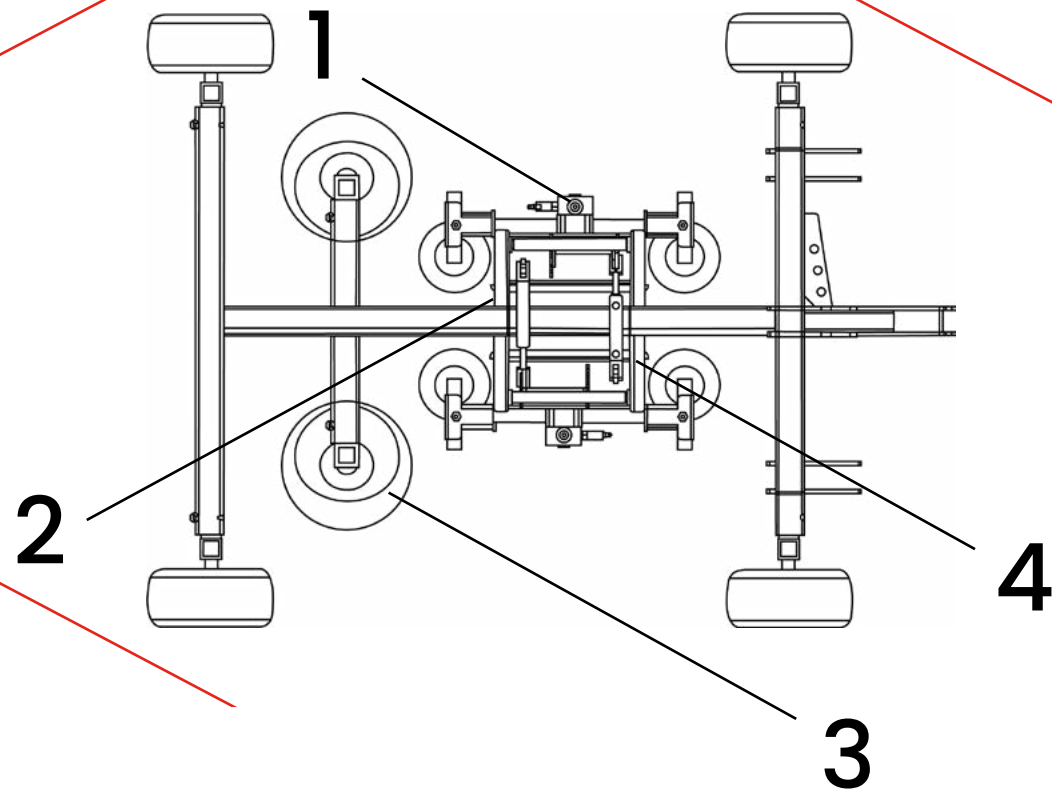

system in detail

- 1** The blades are guided parallel to the dam flank and safely cut off the tendrils.
- 2** Housing suspended in pendulum fashion, ensuring exact adaptation to a wide variety of dam shapes.

- 3** Pulled base frame with feeler wheels guides itself along the strawberry dam.
- 4** Hydraulically swing-out housings for safe retraction and extension at the field ends.

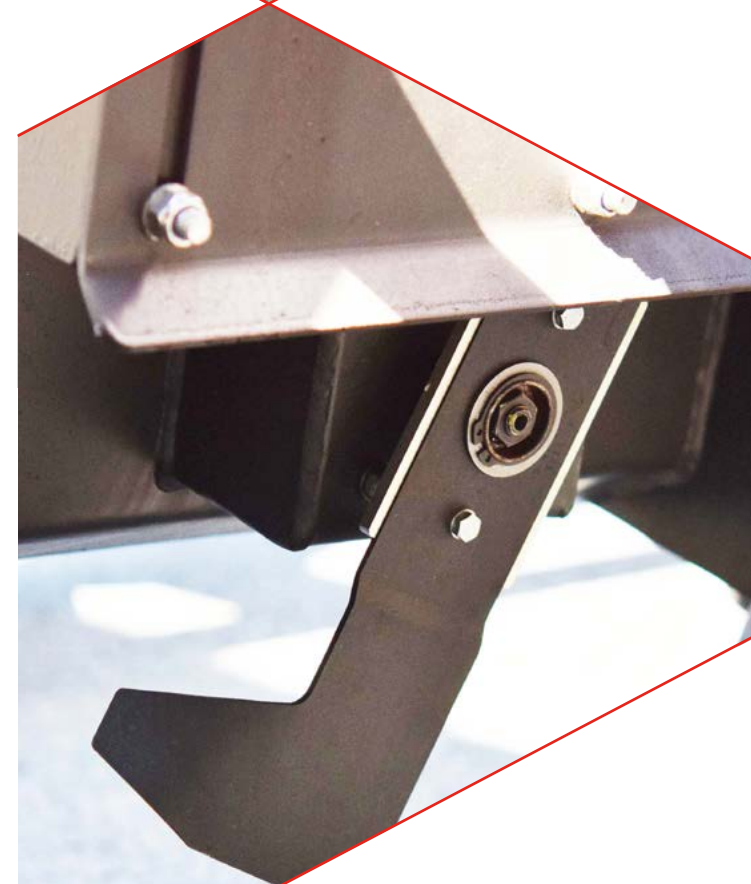

4DISC
RANEX